

Since 1949
Slant/Fin
BASEBOARD

Multi/Pak® 88

High Capacity Hot Water Baseboard



Made with Commercial Grade
RUST-RESISTANT
Galvanized Steel!



Multi/Pak® 88

Six interchangeable heating elements in one low profile enclosure for any residential or light commercial job.

The Ultimate in Flexibility and Design

Multi/Pak® 88 is a heavy-duty baseboard heating product that provides specifying engineers and contractors a choice of six interchangeable high output heating elements in one low profile enclosure. This allows for more design flexibility than any competitor's baseboard. The low profile design makes it ideal where space is at a premium, while the extra-high heat outputs of all six elements meet nearly every heating requirement.

One of the most rugged baseboards available for any residential or light commercial installation, its galvanized steel enclosure and heavy-duty support brackets make Multi/Pak 88 ideal for heavy traffic areas such as offices, apartments and building corridors as well as any home. Furnished in a white baked enamel finish that blends with any decor, Multi/Pak 88 also features a fully modulating damper for individual room control and its "easy glide" expansion cradles assure noise free operation. For high-capacity baseboard heating at a competitive price, specify Multi/Pak 88.

Snap-On Dampers

Finger-touch snap-on damper can be opened and closed without the use of hinges which can bind or loosen with age.

Heavy-Duty Front Panel

With a rugged 18-gauge galvanized steel enclosure, there's none heavier in the industry. This sturdy enclosure resists dents and always looks new, year after year.

Easy Installation

All copper/aluminum heating elements have an expanded end for easy sweat connections without couplings. The 1-1/4" IPS steel element is threaded at both ends.

Rugged Support Brackets

Multi/Pak 88 is constructed with strong, heavy gauge support brackets which will stand up to years of wear and tear without bending or tattering in any way.

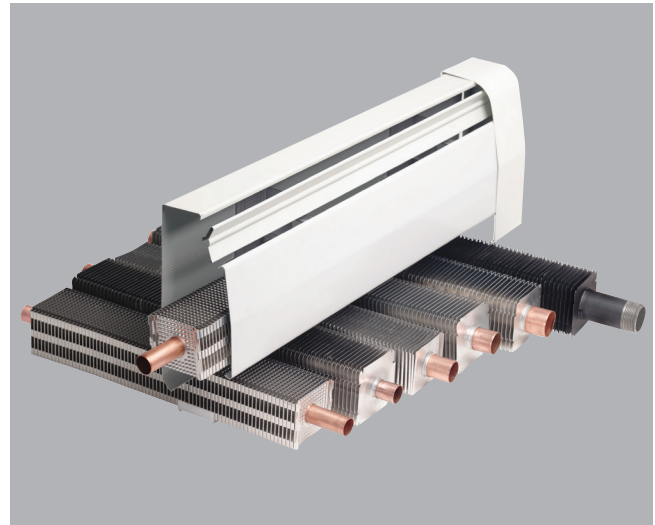

Tube Support System

Multi/Pak 88's unique tube support design allows for fast and easy installation of a return line.

Six Interchangeable Elements

With a choice of six interchangeable elements, each with a different output and capacity, our Multi/Pak 88 is ideal for virtually any type of installation.

Copper/Aluminum Elements:

H1 (3/4" with 3-1/4" x 3-1/4" fins)

H3 (3/4" with 2-1/2" x 2-3/4" fins)

H4 (1" with 2-1/2" x 2-3/4" fins)

H2 (1" with 3-1/4" x 3-1/4" fins)

H5 (1-1/4" with 3-1/4" x 3-1/4" fins)





IPS Steel Elements:

H6 (1-1/4" with 3-1/4" x 3-1/4" fins)

Expansion Cradles

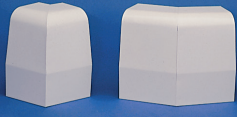
Easy glide polypropylene expansion cradles are attached to the fins on all six elements over the support brackets, which eliminate noisy metal to metal contact between the brackets and the enclosure. This guarantees smooth, quiet operation for years to come.

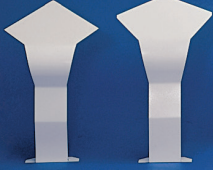
Accessories

| | | | |
|---|--|--|--|
|  | <p>End Cap 3" wide left and right, for use at doorways and wherever a finished end is needed. 3" wide slotted left and right, for through-the-wall connections. Fully telescopic.</p> |  | |
|  |  |  | <p>Outside Corner 90° and 135°/45°. Use to trim corners at projecting wall. Telescopic up to 1" on each wall.</p> |
| <p>Valve Enclosure 9" wide left and right. Extra wide 6" hinged door for easy access to valve or vent. Fully telescopic.</p> | <p>Valve Enclosure (slotted) 9" wide left and right. Extra wide 6" hinged door for easy access to valve or vent. Fully telescopic.</p> | <p>Inside Corner 90° and 135°/45°. One piece snap-on for easy installation. Telescopic up to 2-1/2" on each wall.</p> | |
|  | <p>Extension Sets 14" wide. Four sections (back, front, top and damper). Telescopes to fill gaps up to 12-1/2" between baseboard panels.</p> |  | <p>Wall Joiners 5" and 9". Fully telescopic to conceal connecting pipes.</p> |

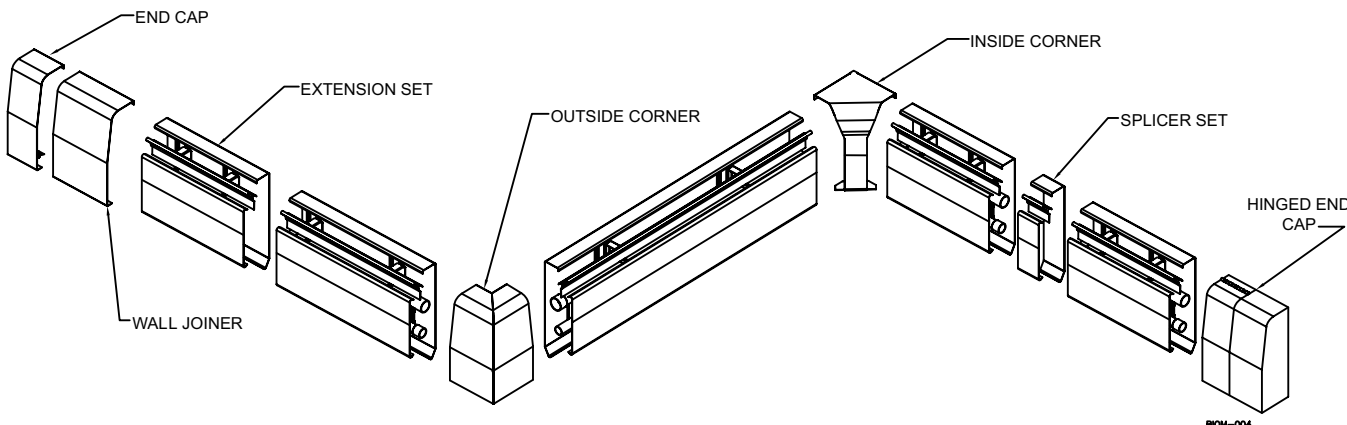

Specifications

Ratings

| Element Type | Tube Size & Material | Fin Size & Material | Water Flow (GPM) | Average Hot Water Temperature - BTU/Hr./Lin./Ft. | | | | | | | | | |
|--------------|----------------------|---|------------------|--|-------|-------|-------|-------|-------|-------|-------|-------|-------|
| | | | | 120°F | 130°F | 140°F | 150°F | 160°F | 170°F | 180°F | 190°F | 200°F | 210°F |
| H1 | 3/4" Copper | 3 1/4" x 3 1/4" x .018 aluminum | 4 | 316 | 401 | 486 | 547 | 644 | 770 | 870 | 970 | 1070 | 1160 |
| | | | 1 | 299 | 380 | 460 | 518 | 610 | 730 | 820 | 920 | 1010 | 1100 |
| H3 | 3/4" Copper | 2 1/2" x 2 3/4" x .011 aluminum | 4 | 269 | 342 | 414 | 466 | 549 | 640 | 740 | 820 | 910 | 990 |
| | | | 1 | 255 | 323 | 392 | 441 | 519 | 610 | 700 | 780 | 860 | 940 |
| H4 | 1" Copper | 2 1/2" x 2 3/4" x .011 aluminum | 4 | 267 | 338 | 410 | 461 | 543 | 640 | 730 | 810 | 900 | 980 |
| | | | 1 | 252 | 320 | 388 | 437 | 514 | 610 | 690 | 770 | 850 | 930 |
| H2 | 1" Copper | 3 1/4" x 3 1/4" x .018 aluminum | 4 | 307 | 389 | 472 | 531 | 625 | 740 | 840 | 930 | 1040 | 1130 |
| | | | 1 | 290 | 368 | 446 | 502 | 591 | 700 | 790 | 880 | 980 | 1070 |
| H5 | 1 1/4" Copper | 3 1/4" x 3 1/4" x .018 aluminum | 4 | 295 | 375 | 454 | 511 | 602 | 710 | 800 | 900 | 990 | 1090 |
| | | | 1 | 306 | 388 | 470 | 529 | 623 | 670 | 760 | 850 | 940 | 1030 |
| H6 | 1 1/4" IPS Steel | 3 1/4" x 3 1/4" x .026 electro-gal. steel | 4 | 252 | 320 | 388 | 437 | 514 | 610 | 690 | 770 | 850 | 930 |
| | | | 1 | 239 | 304 | 368 | 414 | 488 | 580 | 650 | 730 | 800 | 880 |

NOTE: All the above ratings are based on active length, which is 4" less than total length, and includes a 15% addition for heating effect.

The use of these ratings at 2000 lb/hr is limited to installations where the water flow rate through the baseboard unit is equal to or greater than 2000 lb/hr. Where the flow rate through the baseboard is not known; the rating at 500 lb/hr. must be used.

Dimensional Data

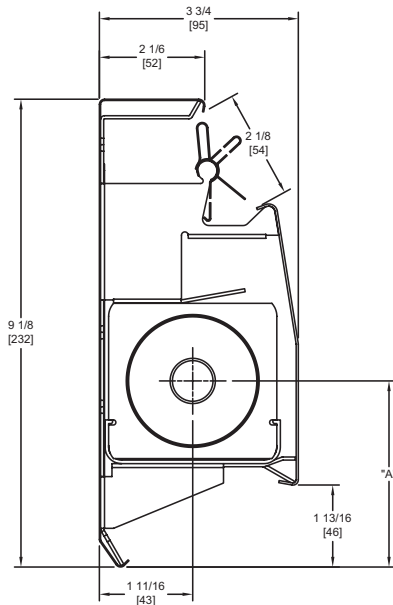

"A" DIMENSIONS

| Dimension | H1 | H3 | H4 | H2 | H5 | H6 |
|-----------|--------|--------|--------|--------|--------|--------|
| "A" | 3 5/8" | 3 1/2" | 3 1/2" | 3 5/8" | 3 5/8" | 3 5/8" |

H1 Element

3/4" Nominal Copper Tubing with 3 1/4"x3-1/4"x.018" thick aluminum fins (natural finish) x 51 fins per ft. Pressure Drop (in ft. of head per 100 ft. - ft./100 ft.) @ 1 GPM = 0.32 ft./100 ft. and @ 4 GPM = 4.16 ft./100 ft. Bursting Pressure 1412 psi.; Operating Pressure 283 psi.

H3 Element

3/4" Nominal Copper Tubing with 2-1/2"x2-3/4"x.010" thick aluminum fins (natural finish) x 58 fins per ft. Pressure Drop (in ft. of head per 100 ft. - ft./100 ft.) @ 1 GPM = 0.32 ft./100 ft. and @ 4 GPM = 4.16 ft./100 ft. Bursting Pressure 1412 psi.; Operating Pressure 283 psi.

H4 Element

1" Nominal Copper Tubing with 2-1/2"x2-3/4"x.011" thick aluminum fins (natural finish) x 58 fins per ft. Pressure Drop (in ft. of head per 100 ft. - ft./100 ft.) @ 1 GPM = 0.09 ft./100 ft. and @ 4 GPM = 1.13 ft./100 ft. Bursting Pressure 1082 psi.; Operating Pressure 216 psi.

H2 Element

1" Nominal Copper Tubing with 3 1/4"x3-1/4"x.018" thick aluminum fins (natural finish) x 51 fins per ft. Pressure Drop (in ft. of head per 100 ft. - ft./100 ft.) @ 1 GPM = 0.09 ft./100 ft. and @ 4 GPM = 1.13 ft./100 ft. Bursting Pressure 1082 psi.; Operating Pressure 216 psi.

H5 Element

1-1/4" Nominal Copper Tubing with 3 1/4"x3-1/4"x.018" thick aluminum fins (natural finish) x 51.5 fins per ft. Pressure Drop (in ft. of head per 100 ft. - ft./100 ft.) @ 1 GPM = 0.03 ft./100 ft. and @ 4 GPM = 0.41 ft./100 ft. Bursting Pressure 1556 psi.; Operating Pressure 311 psi.

H6 Element

1-1/4" IPS Steel Pipe with 3 1/4"x3-1/4"x.026" thick steel fins (painted finish) x 48 fins per ft. Pressure Drop @ 4 GPM = 0.35 ft./100 ft. Both ends threaded. Bursting Pressure 7590 psi.; Operating Pressure 1000 psi.