



## Series 14-B Ball Type Blow Down Valve

### Applications:

For Series 47, 67, and 70 boiler control blow down valve replacement.



### **WARNING**

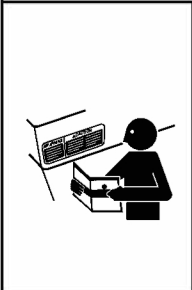

- Before using this product read and understand instructions.
- Save these instructions for future reference.
- All work must be performed by qualified personnel trained in the proper application, installation, and maintenance of plumbing, steam, and electrical equipment and/or systems in accordance with all applicable codes and ordinances.



- To prevent serious burns, wear heat resistant gloves when opening and closing valves, or handling hot equipment.
- To prevent serious burns, allow the control and surrounding equipment to cool to 80°F (27°C) and allow pressure to release to 0 psi (0 bar) before servicing.
- When flushing control (blow down), hot water and steam will flow out. To prevent serious personal injury, connect a drain pipe to the control opening to avoid exposure to steam discharge.
- To prevent flooding, do not puncture float.



- This product can expose you to chemicals including Lead, which is known to the State of California to cause cancer and birth defects or other reproductive harm. For more information go to: [www.P65Warnings.ca.gov](http://www.P65Warnings.ca.gov).
- Previous controls should never be installed on a new system. Always install new controls on a new boiler or system.

Failure to follow this warning could cause property damage, personal injury or death.

**CAUTION:**

- A more frequent replacement interval may be necessary based on the condition of the unit at time of inspection. McDonnell & Miller's warranty is one (1) year from date of installation or two (2) years from the date of manufacture.

# INSTALLATION –

## TOOLS NEEDED:

One (1) flathead screwdriver, one (1) scraper, one (1) pipe wrench, one (1) hammer, and pipe sealing compound.

## STEP 1 - Preparation

### CAUTION



To prevent serious burns, wear heat resistant gloves when opening and closing valves, or handling hot equipment.



To prevent serious burns, allow the control and surrounding equipment to cool to 80°F (27°C) and allow pressure to release to 0 psi (0 bar) before servicing.

Failure to follow this caution could cause personal injury.

- a. Shut off the boiler and disconnect the power to the entire boiler system.

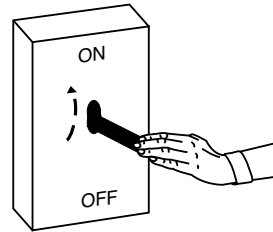

- b. Shut off the inlet water supply by closing the make up water feed valve.

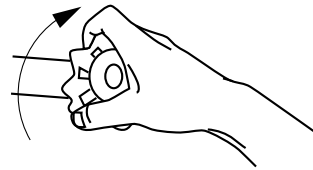

- c. Open the blow down valve (D). Drain the control (A) to a point where no additional water can enter the control. Let the control (A) and surrounding equipment to cool to 80°F (27°C) and allow pressure to release to 0 psi (0 bar).

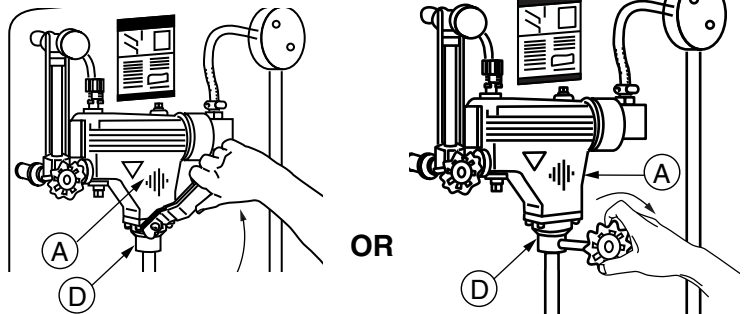

- d. Using a pipe wrench (B), remove the blow down pipe (C) from the existing blow down valve (D).

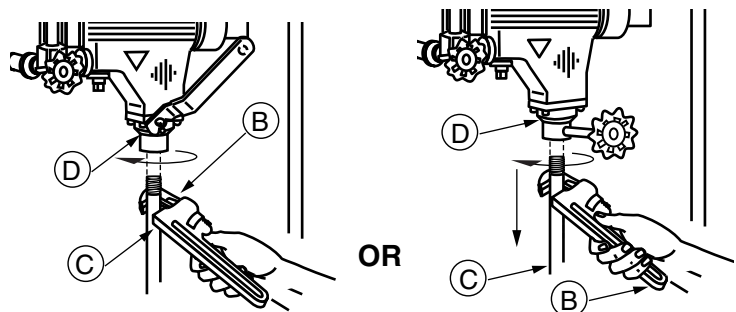

- e. Using a flathead screwdriver (E), loosen the four (4) screws.

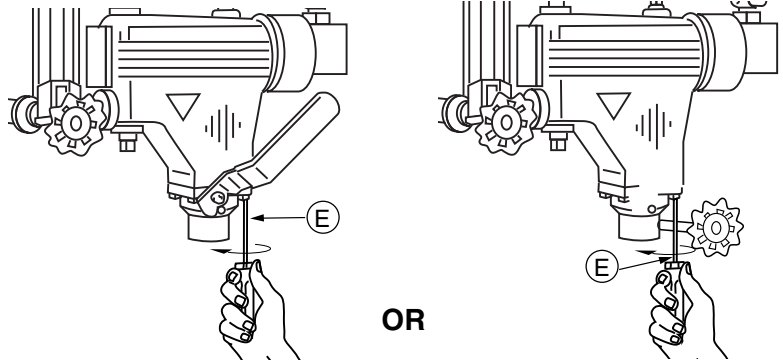

- f. Remove the blow down valve (D) from the control (A). If necessary, use a hammer to tap it loose.

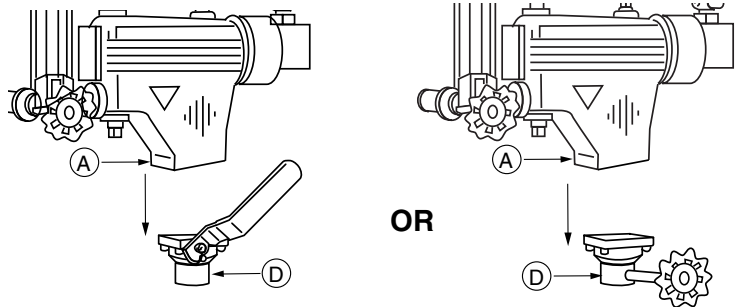

NOTE: For spring type blow down valves, the spring mechanism must be removed from the control body.



### CAUTION

To prevent flooding, do not puncture float.

Failure to follow this caution could cause property damage.

- g. Inspect the float chamber (E) for debris. Carefully remove any debris, mud, or other foreign matter which may obstruct the float's full range of motion, without puncturing the float.

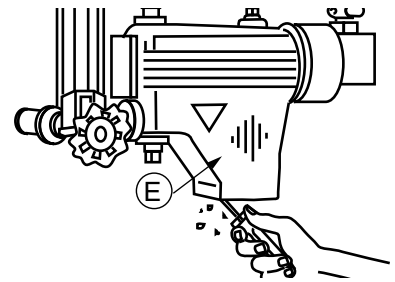

- h. Using a scraper, remove the old gasket (F) from the control (A). The gasket sealing surface (G) must be smooth and clean for proper installation.

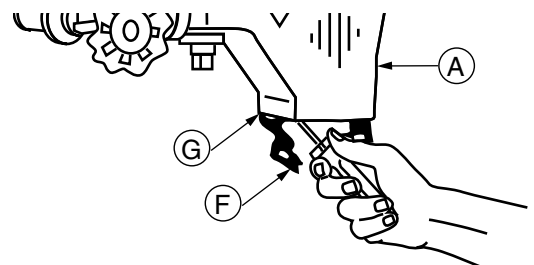

## STEP 2 - Installing the New Blow Down Valve

- a. Hold the new replacement blow down valve (H) upright and remove the rubber band around the valve body.

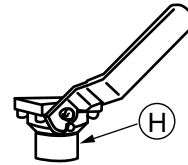

**Be careful not to tip the valve as its components might fall out.** If this occurs, reassemble as shown (J).

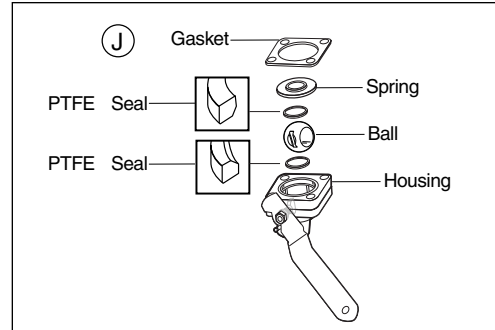

- b. Position the blow down valve (H) onto the control's mating surface (G). So that its handle (K) is accessible and is able to swing through its full range of motion (90°).

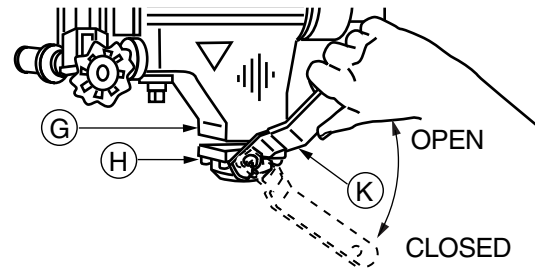

- c. Insert the four (4) screws provided through the blow down valve and gasket (D) into the threaded holes on the mating surface (G).

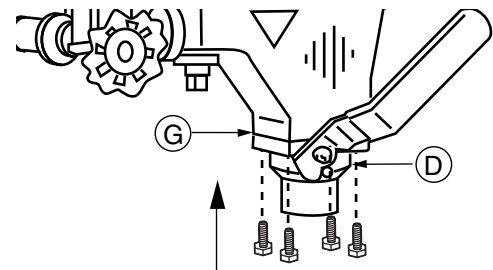

- d. Using a flathead screwdriver (L), tighten the screws to approximately 15 ft•lb (20 N•m).

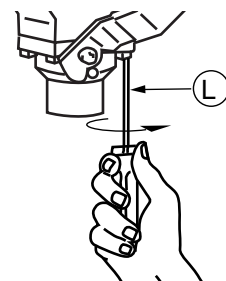

- e. Verify that the blow down valve (H) is unobstructed by opening and closing the valve over its full range of motion (90°).

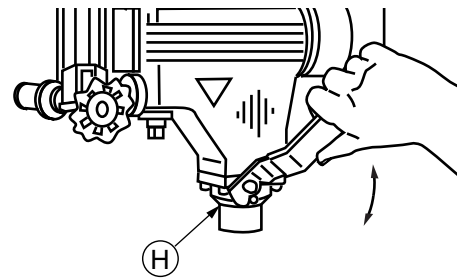

- f. Apply pipe sealing compound to the threaded end of a 3/4" (20mm) NPT blow down pipe (M) and screw it into the control (N). Tighten the pipe (M) with a pipe wrench (P) to approximately 47 ft•lb (64 N•m).

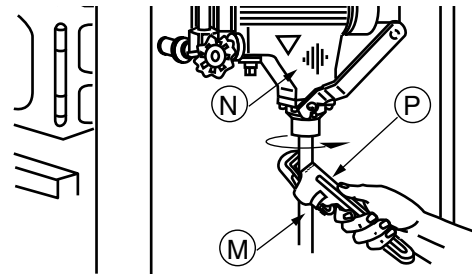

- g. Turn the blow down valve handle (K) to its closed position.

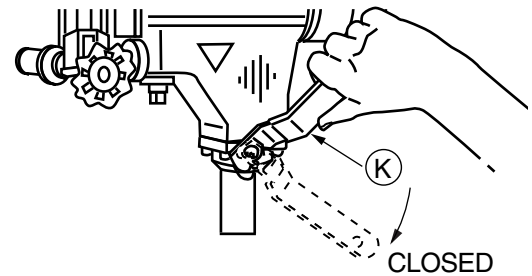

- h. Hang the enclosed blow down card (Q) as close to the control as possible, or remove the protective backing and affix the card on the boiler jacket close to the control.

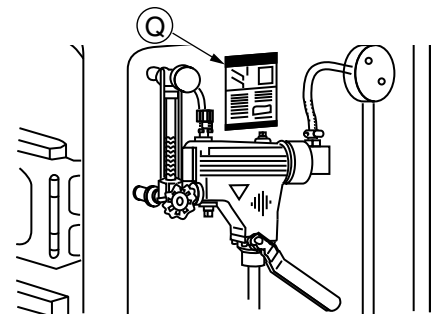

## STEP 3 - Testing

- a. Make sure that the blow down valve handle (K) is in its closed position.

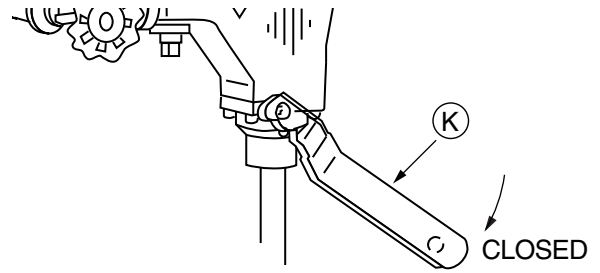

- b. Open the make-up water feed valve.

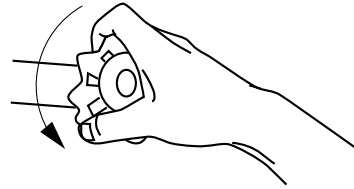

- c. Turn on the power to the boiler system and turn on the boiler.

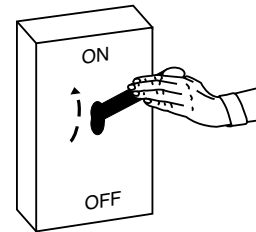

- d. Verify that the burner is off and that the system is filling with water by observing the water level rise in the gauge glass (R)

**IMPORTANT:** The burner must not turn on until the water level has reached its minimum safe operating level as determined by the boiler manufacturer. If the burner turns on before this point, immediately shut off the boiler and correct the problem. Other equipment may be involved and the system should be inspected by qualified personnel.

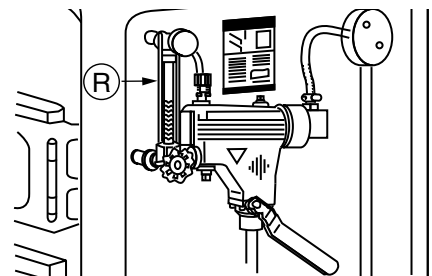

e. Allow the system to build to its normal operating pressure and check for leakage around the mating surface (G), the shaft (S), and the pipe opening (T).

1. If leakage occurs around the mating surface (G), retighten the four (4) screws. If leakage continues, follow "Step 1" to remove the blow down valve (H). Closely following the installation instructions, replace it.
2. If leakage occurs around the valve shaft (S), follow "Step 1" to remove the blow down valve (H). Closely following the installation instructions, replace it.
3. If leakage occurs around the pipe outlet (T), follow "Step 1" to remove the blow down valve (H) and verify that it has been properly assembled as shown in "Step 2-a". Inspect the blow down valve (H) for debris which may prevent it from completely closing or sealing. If leakage continues, follow "Step 1" to remove it. Closely following the installation instructions, replace the blow down valve (H).

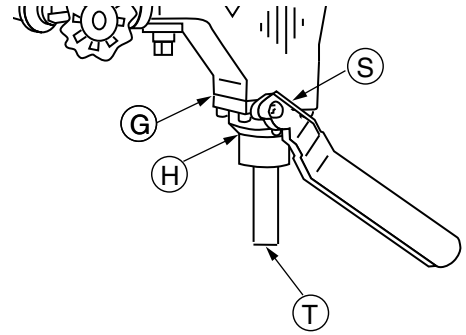

**WARNING**



To prevent serious personal injury from steam blow down, connect a drain pipe to avoid exposure to steam discharge.

Failure to follow this caution could cause personal injury or death.

f. Open the blow down valve (H) to "blow down" the control (A). The burner should shut-off.

**IMPORTANT:** If the control (A) does not blow down and/or the burner does not shut-off, close the blow down valve (H), immediately shut off the boiler, and correct the problem. Other equipment may be involved and the system should be inspected by qualified personnel.

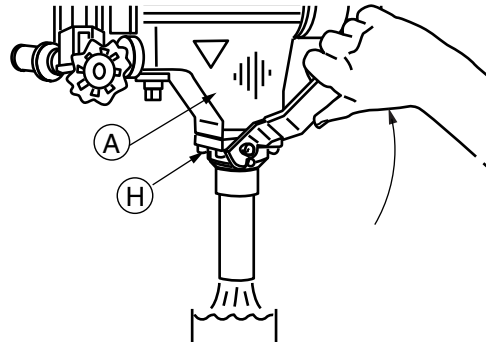

g. Close the blow down valve (H) and check for leakage by following the instructions in "Step 3" section e.

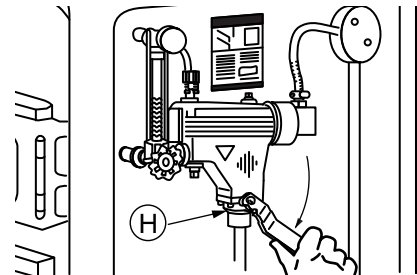

**INSTALLATION COMPLETE**

# MAINTENANCE

## SCHEDULE:

- Blow down weekly when the boiler is in operation.
- Disassemble and inspect annually. Replace the control if it is worn, corroded, or if components no longer operate properly.
- Inspect the float chamber and equalizing piping annually. Remove all sediment and debris.
- Replace the blow down valve every 10 years. More frequent replacement may be required if it is used in locales where significant water treatment is required, where more frequent cleaning is necessary, or in applications with high make-up water requirements.

## PROCEDURE:

|                                                                                                    |                                                                                                                          |
|----------------------------------------------------------------------------------------------------|--------------------------------------------------------------------------------------------------------------------------|
|  <b>CAUTION</b> |                                                                                                                          |
|                   | To prevent serious personal injury from steam pipe blow down, connect a drain pipe to avoid exposure to steam discharge. |
|                                                                                                    | Failure to follow this caution could cause personal injury.                                                              |

1. Blow down the low water cut-off when the water level is at its normal level and the burner is on. **Slowly** open the blow down valve until it is fully open and observe the water level fall in the gauge glass. Close the valve after verifying that the burner shuts off. If this does not happen, immediately shut off the boiler and correct the problem.

### COMMERCIAL WARRANTY

**Warranty.** For goods sold to commercial buyers, Seller warrants the goods sold to Buyer hereunder (with the exception of membranes, seals, gaskets, elastomer materials, coatings and other "wear parts" or consumables all of which are not warranted except as otherwise provided in the quotation or sales form) will be (i) be built in accordance with the specifications referred to in the quotation or sales form, if such specifications are expressly made a part of this Agreement, and (ii) free from defects in material and workmanship for a period of one (1) year from the date of installation or two (2) years from the date of manufacture, whichever shall occur first, unless a longer period is specified in the product documentation (the "Warranty").

Except as otherwise required by law, Seller shall, at its option and at no cost to Buyer, either repair or replace any product which fails to conform with the Warranty provided Buyer gives written notice to Seller of any defects in material or workmanship within ten (10) days of the date when any defects or non-conformance are first manifest. Under either repair or replacement option, Seller shall not be obligated to remove or pay for the removal of the defective product or install or pay for the installation of the replaced or repaired product and Buyer shall be responsible for all other costs, including, but not limited to, service costs, shipping fees and expenses. Seller shall have sole discretion as to the method or means of repair or replacement. Buyer's failure to comply with Seller's repair or replacement directions shall terminate Seller's obligations under this Warranty and render the Warranty void. Any parts repaired or replaced under the Warranty are warranted only for the balance of the warranty period on the parts that were repaired or replaced. Seller shall have no warranty obligations to Buyer with respect to any product or parts of a product that have been: (a) repaired by third parties other than Seller or without Seller's written approval; (b) subject to misuse, misapplication, neglect, alteration, accident, or physical damage; (c) used in a manner contrary to Seller's instructions for installation, operation and maintenance; (d) damaged from ordinary wear and tear, corrosion, or chemical attack; (e) damaged due to abnormal conditions, vibration, failure to properly prime, or operation without flow; (f) damaged due to a defective power supply or improper electrical protection; or (g) damaged resulting from the use of accessory equipment not sold or approved by Seller. In any case of products not manufactured by Seller, there is no warranty from Seller; however, Seller will extend to Buyer any warranty received from Seller's supplier of such products.

**THE FOREGOING WARRANTY IS EXCLUSIVE AND IN LIEU OF ANY AND ALL OTHER EXPRESS OR IMPLIED WARRANTIES, GUARANTEES, CONDITIONS OR TERMS OF WHATEVER NATURE RELATING TO THE GOODS PROVIDED HEREUNDER, INCLUDING WITHOUT LIMITATION ANY IMPLIED WARRANTIES OF MERCHANTABILITY AND FITNESS FOR A PARTICULAR PURPOSE, WHICH ARE HEREBY EXPRESSLY DISCLAIMED AND EXCLUDED. EXCEPT AS OTHERWISE REQUIRED BY LAW, BUYER'S EXCLUSIVE REMEDY AND SELLER'S AGGREGATE LIABILITY FOR BREACH OF ANY OF THE FOREGOING WARRANTIES ARE LIMITED TO REPAIRING OR REPLACING THE PRODUCT AND SHALL IN ALL CASES BE LIMITED TO THE AMOUNT PAID BY THE BUYER FOR THE DEFECTIVE PRODUCT. IN NO EVENT SHALL SELLER BE LIABLE FOR ANY OTHER FORM OF DAMAGES, WHETHER DIRECT, INDIRECT, LIQUIDATED, INCIDENTAL, CONSEQUENTIAL, PUNITIVE, EXEMPLARY OR SPECIAL DAMAGES, INCLUDING BUT NOT LIMITED TO LOSS OF PROFIT, LOSS OF ANTICIPATED SAVINGS OR REVENUE, LOSS OF INCOME, LOSS OF BUSINESS, LOSS OF PRODUCTION, LOSS OF OPPORTUNITY OR LOSS OF REPUTATION.**

### LIMITED CONSUMER WARRANTY

**Warranty.** For goods sold for personal, family or household purposes, Seller warrants the goods purchased hereunder (with the exception of membranes, seals, gaskets, elastomer materials, coatings and other "wear parts" or consumables all of which are not warranted except as otherwise provided in the quotation or sales form) will be free from defects in material and workmanship for a period of one (1) year from the date of installation or two (2) years from the product date code, whichever shall occur first, unless a longer period is provided by law or is specified in the product documentation (the "Warranty").

Except as otherwise required by law, Seller shall, at its option and at no cost to Buyer, either repair or replace any product which fails to conform with the Warranty provided Buyer gives written notice to Seller of any defects in material or workmanship within ten (10) days of the date when any defects or non-conformance are first manifest. Under either repair or replacement option, Seller shall not be obligated to remove or pay for the removal of the defective product or install or pay for the installation of the replaced or repaired product and Buyer shall be responsible for all other costs, including, but not limited to, service costs, shipping fees and expenses. Seller shall have sole discretion as to the method or means of repair or replacement. Buyer's failure to comply with Seller's repair or replacement directions shall terminate Seller's obligations under this Warranty and render this Warranty void. Any parts repaired or replaced under the Warranty are warranted only for the balance of the warranty period on the parts that were repaired or replaced. The Warranty is conditioned on Buyer giving written notice to Seller of any defects in material or workmanship of warranted goods within ten (10) days of the date when any defects are first manifest.

Seller shall have no warranty obligations to Buyer with respect to any product or parts of a product that have been: (a) repaired by third parties other than Seller or without Seller's written approval; (b) subject to misuse, misapplication, neglect, alteration, accident, or physical damage; (c) used in a manner contrary to Seller's instructions for installation, operation and maintenance; (d) damaged from ordinary wear and tear, corrosion, or chemical attack; (e) damaged due to abnormal conditions, vibration, failure to properly prime, or operation without flow; (f) damaged due to a defective power supply or improper electrical protection; or (g) damaged resulting from the use of accessory equipment not sold or approved by Seller. In any case of products not manufactured by Seller, there is no warranty from Seller; however, Seller will extend to Buyer any warranty received from Seller's supplier of such products.

**THE FOREGOING WARRANTY IS PROVIDED IN PLACE OF ALL OTHER EXPRESS WARRANTIES. ALL IMPLIED WARRANTIES, INCLUDING BUT NOT LIMITED TO THE IMPLIED WARRANTIES OF MERCHANTABILITY AND FITNESS FOR A PARTICULAR PURPOSE, ARE LIMITED TO ONE (1) YEAR FROM THE DATE OF INSTALLATION OR TWO (2) YEARS FROM THE PRODUCT DATE CODE, WHICHEVER SHALL OCCUR FIRST. EXCEPT AS OTHERWISE REQUIRED BY LAW, BUYER'S EXCLUSIVE REMEDY AND SELLER'S AGGREGATE LIABILITY FOR BREACH OF ANY OF THE FOREGOING WARRANTIES ARE LIMITED TO REPAIRING OR REPLACING THE PRODUCT AND SHALL IN ALL CASES BE LIMITED TO THE AMOUNT PAID BY THE BUYER FOR THE DEFECTIVE PRODUCT. IN NO EVENT SHALL SELLER BE LIABLE FOR ANY OTHER FORM OF DAMAGES, WHETHER DIRECT, INDIRECT, LIQUIDATED, INCIDENTAL, CONSEQUENTIAL, PUNITIVE, EXEMPLARY OR SPECIAL DAMAGES, INCLUDING BUT NOT LIMITED TO LOSS OF PROFIT, LOSS OF ANTICIPATED SAVINGS OR REVENUE, LOSS OF INCOME, LOSS OF BUSINESS, LOSS OF PRODUCTION, LOSS OF OPPORTUNITY OR LOSS OF REPUTATION.**

Some states do not allow limitations on how long an implied warranty lasts, so the above limitation may not apply to you. Some states do not allow the exclusion or limitation of incidental or consequential damages, so the above exclusions may not apply to you. This warranty gives you specific legal rights, and you may also have other rights which may vary from state to state.

To make a warranty claim, check first with the dealer from whom you purchased the product or call +1-847-966-3700 for the name and location of the nearest dealer providing warranty service.

**xylem**  
Let's Solve Water

Xylem Inc.  
8200 N. Austin Avenue  
Morton Grove, Illinois 60053  
Phone: (847) 966-3700  
Fax: (847) 965-8379  
[www.xylem.com/mcdonnellmiller](http://www.xylem.com/mcdonnellmiller)

McDonnell & Miller is a trademark of Xylem Inc. or one of its subsidiaries.  
© 2019 Xylem Inc. MM-7021 June 2019 Part No. 210286

