

Submittal Data

PROJECT:	UNIT TAG:	QUANTITY:
REPRESENTATIVE: _____	TYPE OF SERVICE:	DATE: _____
ENGINEER:	SUBMITTED BY:	DATE:
CONTRACTOR:	APPROVED BY:	DATE:
	ORDER NO.:	DATE:



UPSe 15-58 F

UPSe is a high-efficiency circulator designed for heating systems. It offers high energy savings compared to traditional non-ECM pumps and three control modes that make it suitable for any heating application.

Note! Product picture may differ from actual product

Conditions of Service		Pump Data		Motor Data	
Liquid:	Water	Maximum operating pressure:	175.0 PSI	Mains frequency:	60 Hz
Temperature:	140 °F	Liquid temperature range:	35.6 .. 230 °F		
Specific Gravity:	0.985	Maximum ambient temperature:	131 °F		
		Pipe connection:	GF 15/26		
		Product number:	92603106		

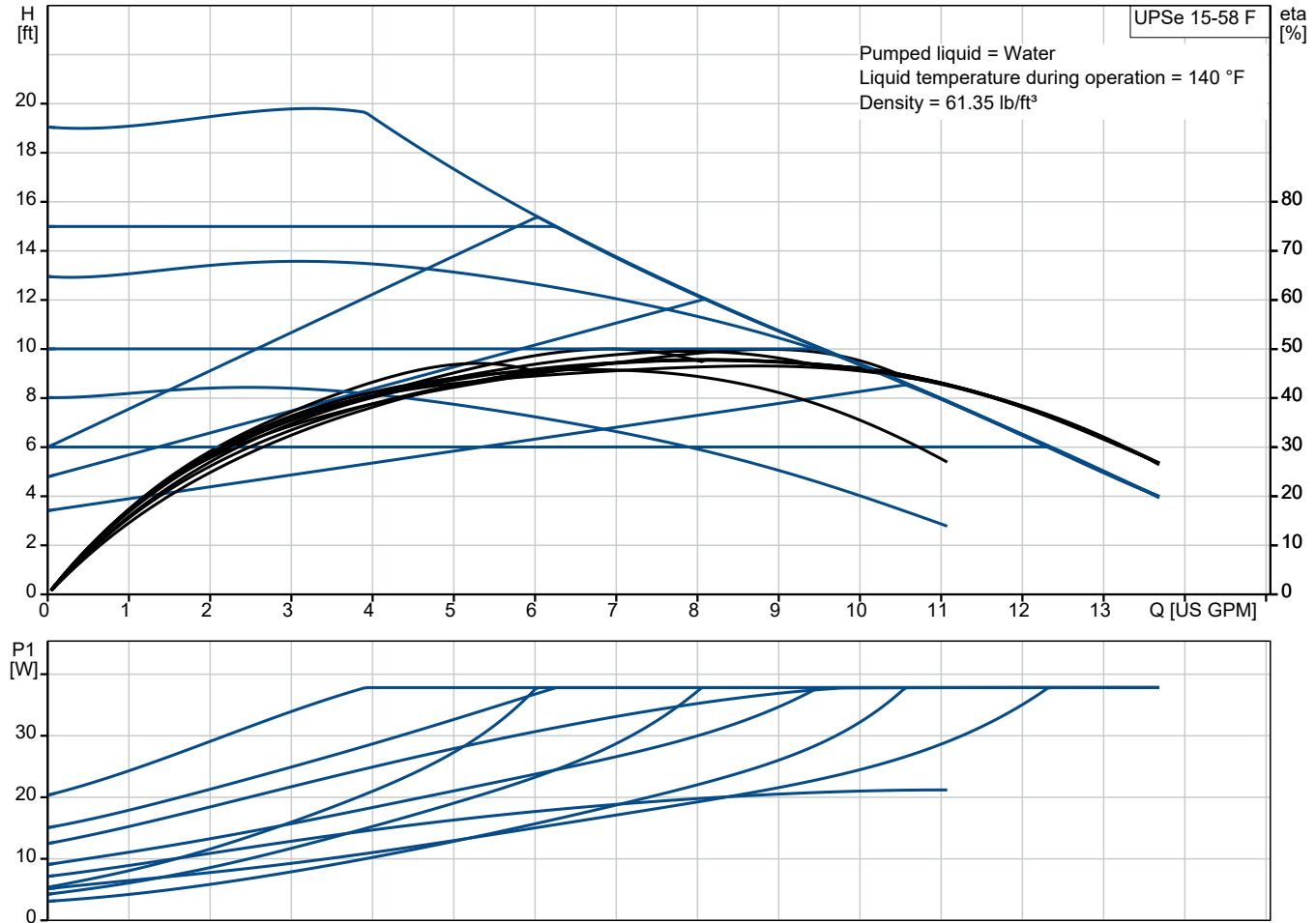

Submittal Data

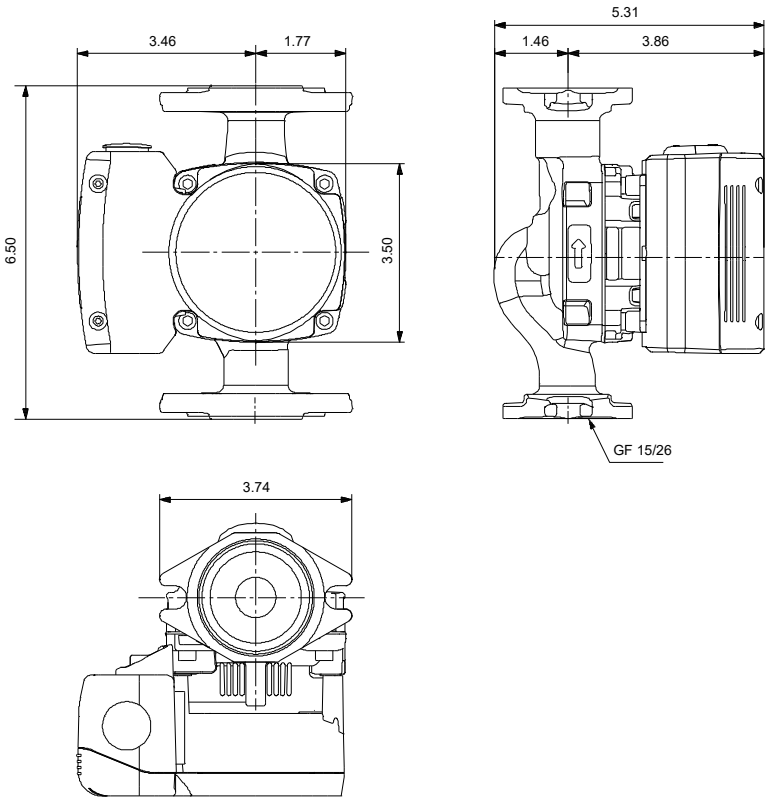

Materials:
Pump housing: Cast iron
Pump housing: ASTM A48-25A
Impeller: Composite

Qty.	Description
------	-------------

1	UPSe 15-58 F
---	--------------



Note! Product picture may differ from actual product

Product No.: [92603106](#)

UPSe is a high-efficiency circulator fitted with an electronically commutated motor. It has been designed for circulating liquids in heating systems and offers the highest energy savings on the market.

The pump features a wide range of controls, featuring constant-pressure, proportional-pressure and constant-speed curve, each with three settings, making it suitable for almost any heating application. With the use of the Grundfos GO replacement compatibility check, it is easier than ever to make your selection.

The new toolless, removeable power connector results in fast and easy installation. Fewer callbacks can be expected due to its robust startup, self-venting ability and dry-running protection. Troubleshooting is also fast and easy by using error codes on the pump user interface.

A terminal box with conduit connections is provided for power connection.



Company name:

Created by:

Phone:

Date:

18/07/2024

92603106 UPSe 15-58 F 60 Hz

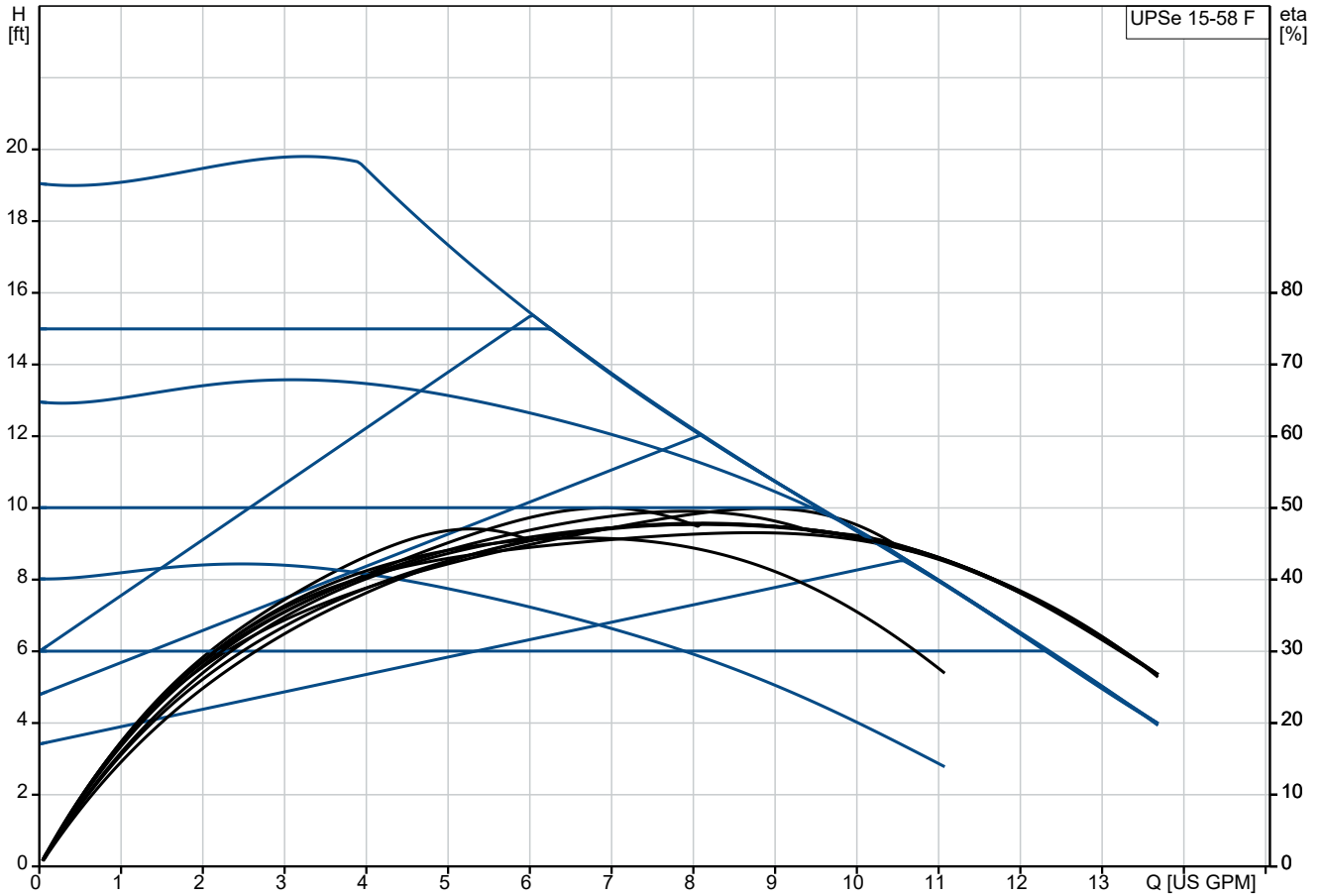

Pumped liquid = Water
Liquid temperature during operation = 140 °F
Density = 61.35 lb/ft³

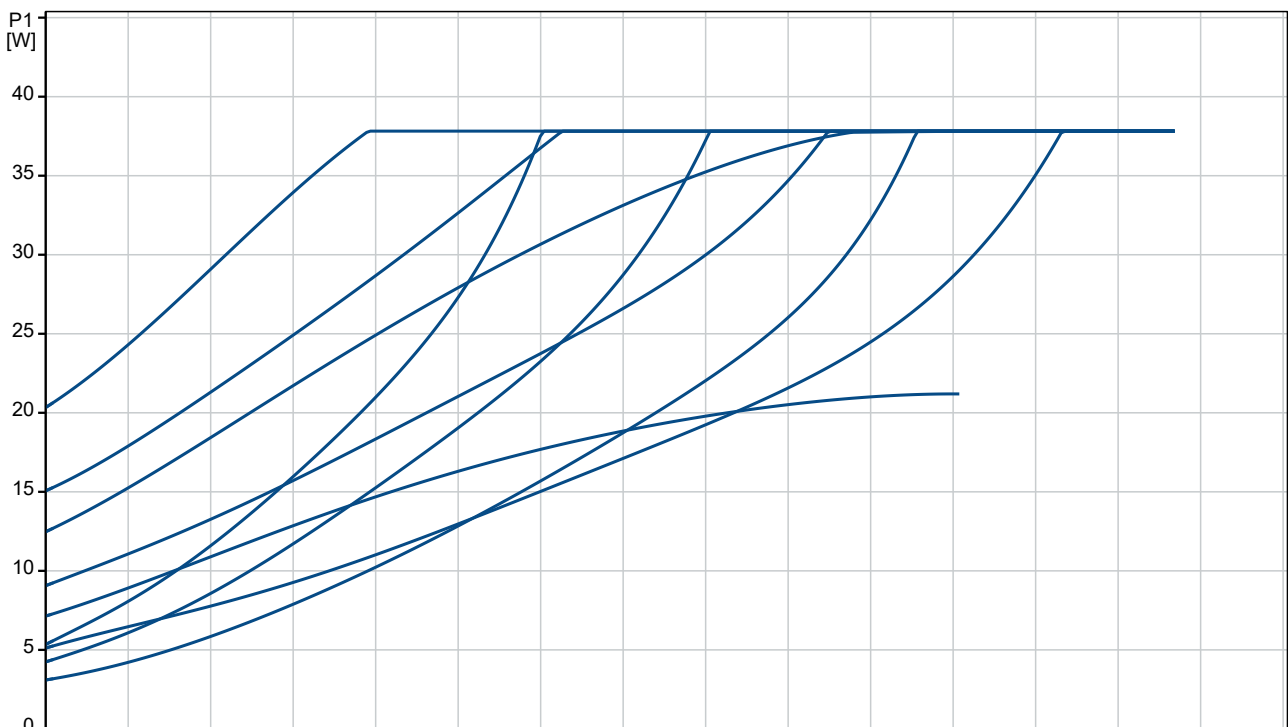

Description	Value
General information:	
Product name:	UPSe 15-58 F
Product No:	92603106
EAN number:	5715116925189
Price:	
Technical:	
Rated flow:	8.37 US GPM
Rated head:	11.16 ft
TF class:	110
Approvals:	FCC,cULus
Model:	A
Materials:	
Pump housing:	Cast iron
Pump housing:	EN 1561 EN-GJL-150
Pump housing:	ASTM A48-25A
Impeller:	Composite
Impeller:	PESU 30% gf + PESU-GF20%
Installation:	
Range of ambient temperature:	32 .. 131 °F
Maximum permissible operating pressure:	175.0 PSI
Pipe connection:	GF 15/26
Pressure rating for connection:	PN 12
Port-to-port length:	6 1/2 in
Liquid:	
Pumped liquid:	Water
Liquid temperature range:	35.6 .. 230 °F
Selected liquid temperature:	140 °F
Density:	61.35 lb/ft³
Electrical data:	
P1 min.:	3.4 W
P1 max.:	38 W
Mains frequency:	60 Hz
Rated voltage:	1 x 115 V
Maximum current consumption:	0.71 A
Enclosure, Type:	2
Others:	
Net weight:	5.29 lb
Gross weight:	5.95 lb
Shipping volume:	0.25 ft³
Sales region:	Namreg
Country of origin:	DK
Custom tariff no.:	8413.70.2005

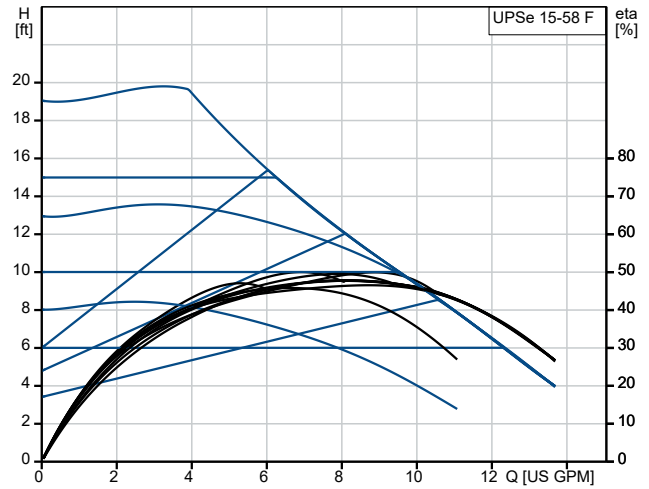

Pumped liquid = Water
 Liquid temperature during operation = 140 °F
 Density = 61.35 lb/ft³

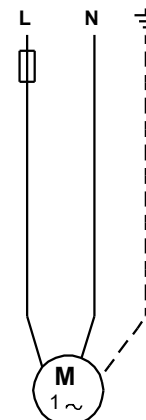
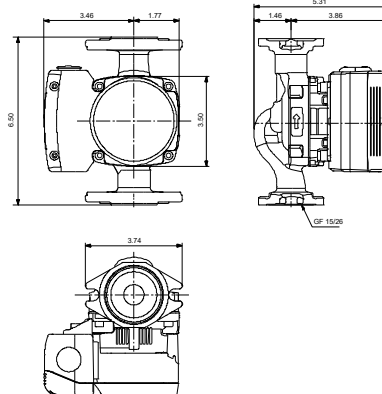
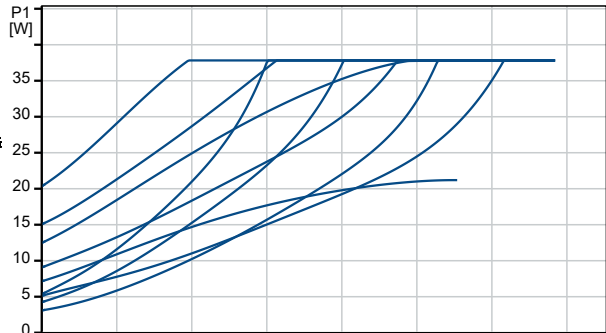

92603106 UPSe 15-58 F 60 Hz

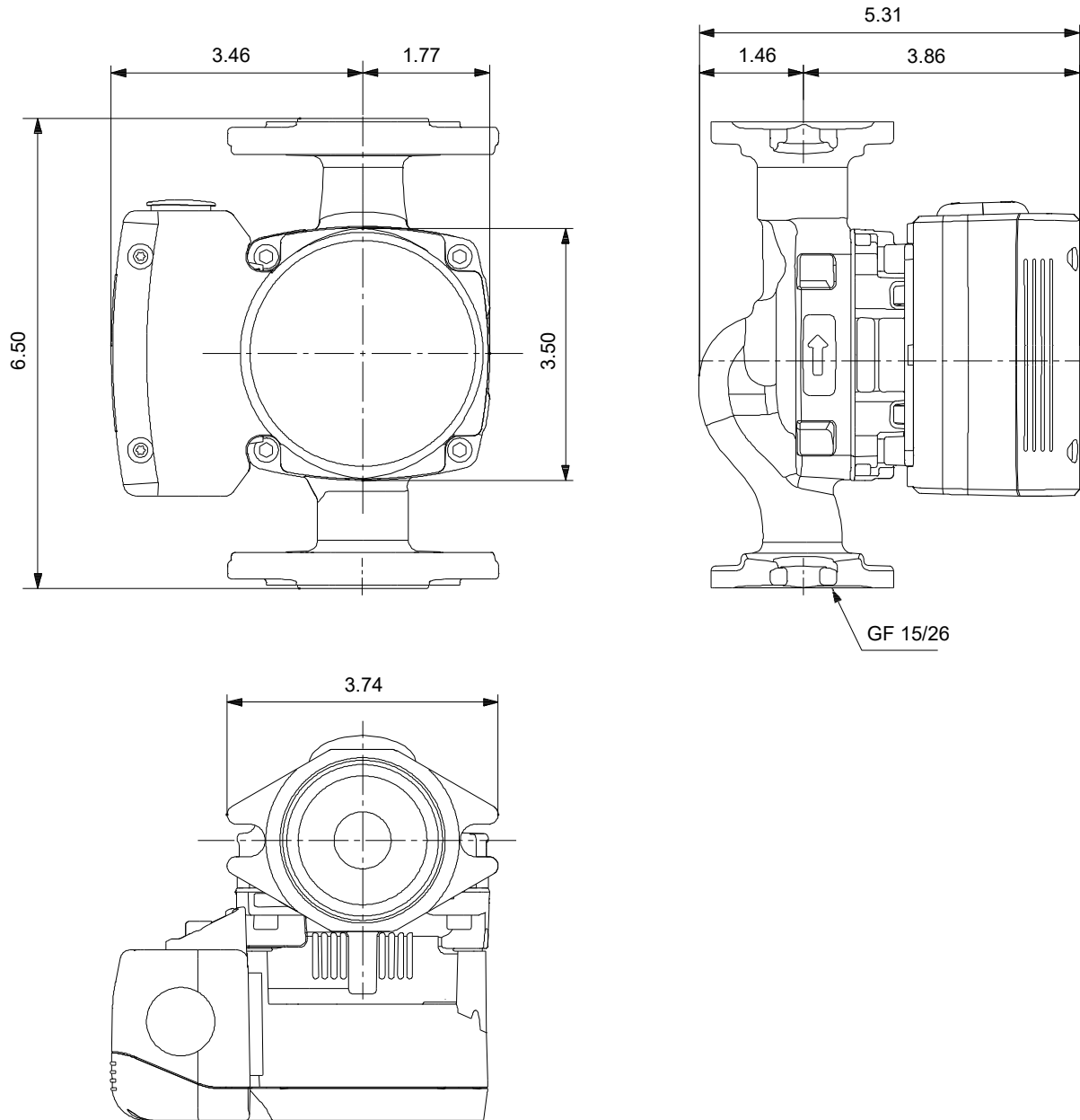

Note! All units are in [in] unless others are stated.
Disclaimer: This simplified dimensional drawing does not show all details.

92603106 UPS_e 15-58 F 60 Hz

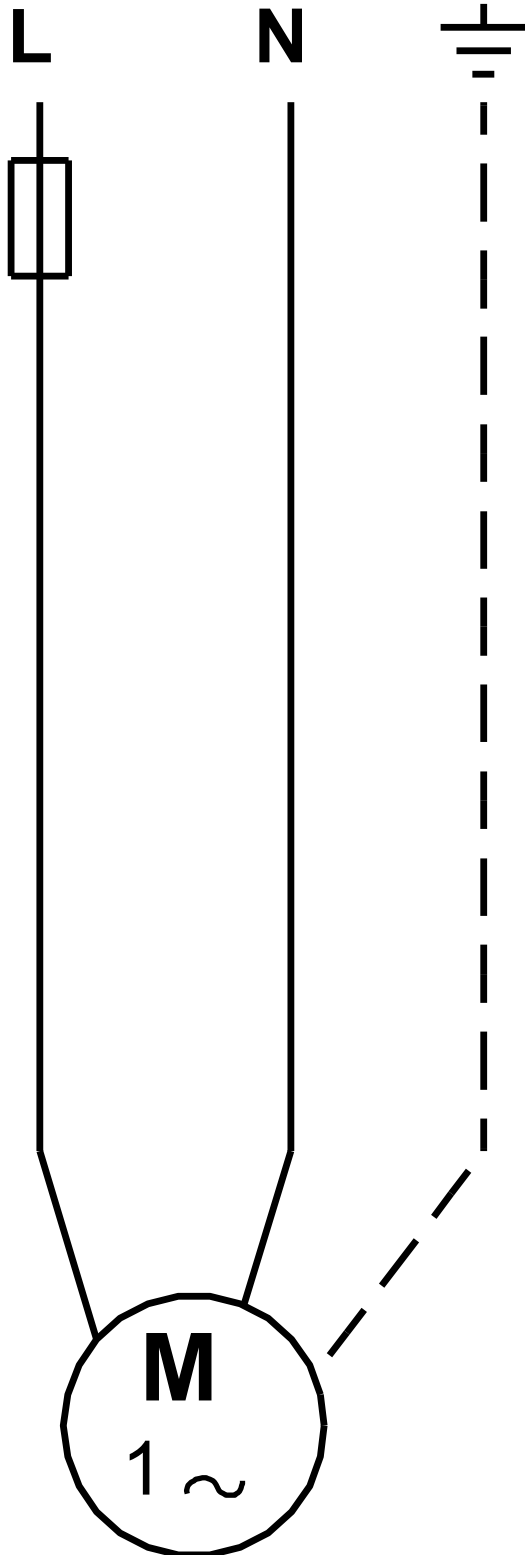

Note! All units are in [in] unless others are stated.

