

## InnoFlue® Fire Rated Wall/Ceiling Penetration Assembly Supplement

InnoFlue® Single Wall Polypropylene Vent Systems can be used in areas that require a one or two hour fire rating per ASTM E-814, UL 1479 or ULC S115 when used with a listed passive fire protection system. Approved passive fire protection system manufacturers include PFP Partners and 3M. This InnoFlue® Fire Rated Assembly Supplement is guideline, the Passive Fire Protection System Manufacturer’s installation instructions should be followed at all times.

### PFP PARTNERS:

InnoFlue 2” through 6” diameter single wall venting has been tested and listed with PFP Partners Passive Fire Stopping Products for a 2 hour fire rating.

Passive Fire Protection Partners  
 1412 Derwent Way  
 Delta BC, Canada  
 V3M-6H9  
 Ph: (800) 810-1788  
<mailto:firestop@firesstop.com>

### Single Penetrations w/ PFP Partners

Horizontal (floor/ceiling)

Test Standards: ASTM E-814, UL 1479, ULC S115-M05

Test Furnace Internal Positive Pressure Differential – 50 Pa (0.2 in. of water)

Penetrating Material & Size	Max. Hole Size	Annular Space	Fire “F” Rating	Fire/Hose “FH” Rating	Temp Rating “FTH” Rating
InnoFlue® SW 2” – 6” (O.D.)	8” (203mm)	1/8 – 1” (3 – 25mm)	Up to 2 Hr	Up to 2 Hr	Up to 2 Hr

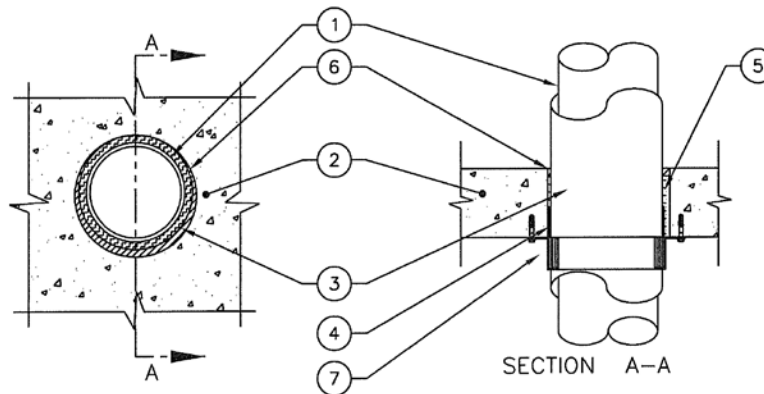

Detail #	Description	Instruction
1	Penetrating Item	InnoFlue SW 2" through 6" vent lengths can be Centered or offset in hole, see table above. Single penetrations only, maximum hole size not to exceed table above.
2	Floor or Wall Assembly	Code conforming 2 hour rated floor or wall assembly having a min. nominal 4 1/2"(115mm) thick lightweight or normal weight concrete or hollow-core concrete. Wall may also be constructed of nominal 8"(203mm) thick concrete blocks (filled or unfilled).
3	InnoFlue Covering Material	Friendly Feel® Duct Wrap with ECOSE® Technology, 3M™ Fire Barrier Plenum Wrap 5A+, Unifrax FyreWrap® 0.5 Plenum Insulation or equivalent fiberglass Insulation with foil – Single layer of 1/2" (12 mm) thick fiberglass insulation installed as per third party agencies Flame Spread and Smoke Development listed installation instructions. Insulation to be tightly butted to top and bottom of collar for both floor or wall assemblies. All seams longitudinal and transverse joints to be sealed with min 2 inch (51mm) wide aluminum foil tape.
4	Firestop System, Component 1	PFP Partners – WS1 Wrap Strip* – Nominal 1/8" (3 mm) thick intumescent material supplied in 2"(50mm) wide strips. Min 1 layer of strip to be wrapped tightly round InnoFlue and fastened in place with aluminum foil tape. Wrap strip to be flush with bottom surface of floor or both sides of the wall.
5	Firestop System, Component 2	Filler material, mineral rock wool insulation with a minimum density of 4-6 PCF (68 kg/m3) compressed a minimum of 25% into the annular space at a minimum depth of 2" (51mm) on each side of the floor or wall assembly. Recess filler material 1/2" (13mm) for sealant placement, not required for wall assemblies. For walls, filler material to be flush with both sides of the assembly.
6	Firestop System,	PFP Partners – Firestop 3600EX*, 4100NS*, 4100SL*, or

	Component 3	4800DW* installed at a minimum thickness of 1/2" (13mm) within the annulus on top surface of floor assembly, not required for wall assemblies. On 0 – 1/4" (0 – 6 mm) annular spaces, a 1/2" (13 mm) diameter fillet bead must be placed around InnoFlue Vent System.
7	Firestop System, Component 4	PFP Partners – Plastic Pipe Collar* (PPC) specifically sized for diameter of InnoFlue. PPC secured to floor/ceiling assembly or wall assembly using 1/4"(6mm) diameter by 1-1/4"(32mm) long steel masonry anchors over fender washers. For walls, the system shall be symmetrical, with PPC installed on each side of the assembly and fixed in the manner as described for floor penetrations.

### 3M:

InnoFlue 2" through 4" diameters can be used with 3M Fire Protection Products to achieve 1 or 2 hr fire rating. Engineering Judgments for 2 hour fire ratings are available from 3M for 6" through 12" diameter InnoFlue Single Wall Vent Systems. Contact Centrotherm or 3M for more information on commercial diameter fire ratings.

Ryan D. Fenstermaker  
 3M Building & Commercial Services / Fire Protection Products  
 Mobile: 732.921.1503 | Fax: 732.432.0616  
[rfenstermaker@mmm.com](mailto:rfenstermaker@mmm.com)

### Single Penetrations w/ 3M

Horizontal (floor/ceiling)

Test Standards: ASTM E- 814, UL 1479, ULC S115-M05

Penetrating Material & Size	Max. Hole Size	Fire "F" Rating	Fire/Hose "FH" Rating	Temp Rating "FTH" Rating
InnoFlue® SW 2" – 4" (O.D.)	10" (252mm)	Up to 2 Hr	Up to 2 Hr	Up to 2 Hr

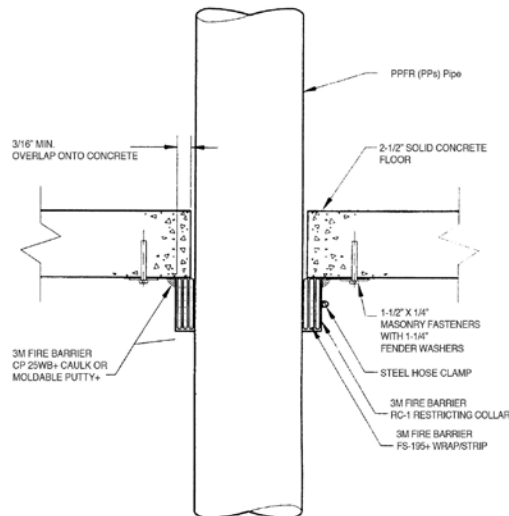

Description	Instruction
Penetrating Item	InnoFlue SW 2" through 6" vent lengths can be Centered or offset in hole, see table above. Single penetrations only, maximum hole size not to exceed table above.
Floor or Wall Assembly	Code conforming 2 hour rated floor or wall assembly of concrete or gypsum.
InnoFlue Covering Material	3M™ Fire Barrier Plenum Wrap 5A+ – Single layer of 1/2" (12 mm) thick fiberglass insulation installed per third party agencies Flame Spread and Smoke Development listed installation instructions. Insulation to be tightly butted to top and bottom of collar for both floor or wall assemblies. All seams longitudinal and transverse joints to be sealed with min 2 in. (51mm) wide aluminum foil tape.
Firestop System, Component 1	3M – FS-195+ Wrap Strips: Tightly wrap the proper number of FS-195+ Wrap Strips around InnoFlue foil side out. Secure with tape or tie wire. Make sure FS-195+ Wrap Strip or PPD butts securely against the concrete with a 3/16" minimum overlap over the edge of the penetrating opening. When using more than one wrap, stagger the butted seams.
Firestop System, Component 2	3M – RC-1 Restricting Collar: Remove enough RC-1 Restricting Collar to make one wrap around the applied FS-195+ Wrap Strip with a minimum 1" overlap. Bend the mounting tabs away from the pipe at right angles, flush with the bottom floor surface. <b>Warning:</b> Edges of RC-1 Restricting Collar are sharp. Handle with care. Tightly secure the RC-1 Restricting Collar around the pipe with a steel hose clamp centered on the RC-1 Restricting Collar assembly. Two bands of 16 gauge steel tie wire placed 1/2 from the ends of the RC-1 Restricting Collar assembly may be used instead of the hose clamp. Secure the collar to the slab with 1/4" x 1 1/2" masonry fasteners. Use 1 1/4" diameter fender washers on the mounting tabs.
Firestop System, Component 3	3M – CP 25WB+ Caulk: Seal the system with 1/4" bead of 3M Fire Barrier CP 25WB+ Caulk or Moldable Putty+ at the concrete and collar assembly interface.