

Wright Valves

Brass Ball Valves — Threaded & Sweat

- Two-Piece Body - Full Port - Blowout-Proof Stem - PTFE Seats
- 1/4" -2" 600 PSI WOG, 2-1/2"-4" 400 PSI WOG, 1/4"-4" 150 PSI WSP
- CSA - ANSI Z21.15/CGA 9.1, ASME B16.44
- CAN/CGA 3.16, ASME B16.33 & ASME B16.38 (Threaded Only)



Threaded

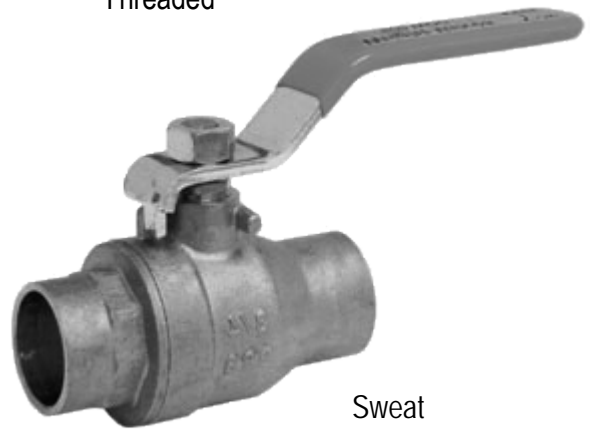

Sweat

MATERIAL LIST

Item	Part	Material
1	Body	Brass
2	End Cap	Brass
3	Ball Seat	PTFE
4	Ball	Brass
5	Stem	Brass
6	Stem Packing	PTFE
7	Packing Nut	Brass
8	Lever Handle	Chrome Plating Steel
9	Stem Nut	Nickel Plating Steel

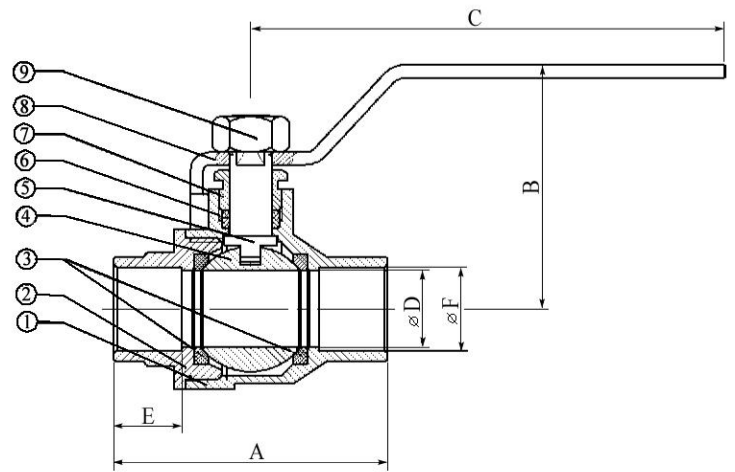
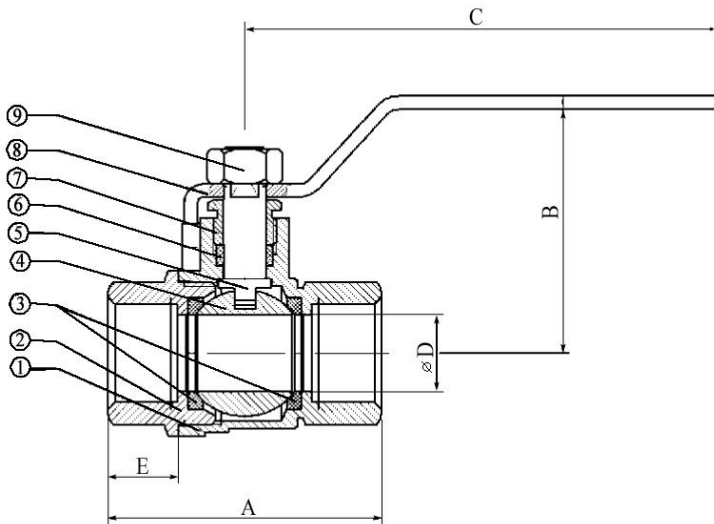
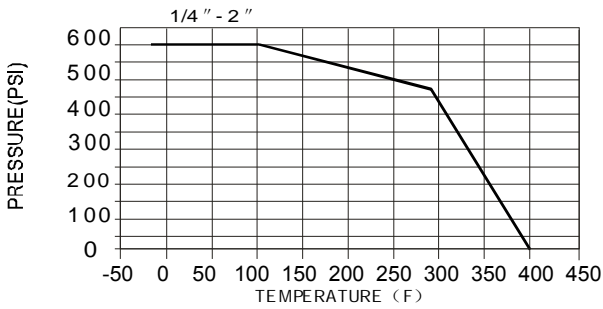

Options-Lever Handle
-Locking Handle

DIMENSIONS

Size	Threaded					Sweat					
	A	B	C	D	E	A	B	C	D	E	F
1/4"	1.667	1.689	2.756	0.315	0.457	-	-	-	-	-	-
3/8"	1.756	1.732	3.543	0.394	0.457	-	-	-	-	-	-
1/2"	2.047	1.921	3.543	0.583	0.520	2.047	1.839	3.543	0.583	0.512	0.630
3/4"	2.362	2.087	3.780	0.748	0.563	2.748	1.996	3.780	0.748	0.748	0.878
1"	2.756	2.559	4.528	0.945	0.630	3.228	2.441	4.528	0.945	0.866	1.130
1 1/4"	3.307	2.953	4.528	1.260	0.709	3.819	2.854	4.528	1.260	0.972	1.378
1 1/2"	3.661	3.346	5.512	1.575	0.717	4.425	3.469	5.512	1.575	1.098	1.630
2"	4.181	3.681	5.512	1.969	0.748	5.315	3.449	5.512	1.969	1.346	3.130

